

TOTO WASHLET

Installation Guide 시공설명서 คำแนะนำในการติดตั้ง Sách hướng dẫn lắp đặt

- Before installation, be sure to read this installation manual. Mount parts properly according to the directions.
- 설치 전에 반드시 설명서를 잘 읽은 후에 바르게 설치해 주십시오.
- กรุณาอ่านคู่มือก่อนการติดตั้งและติดตั้งอย่างถูกต้อง
- Trước khi lắp đặt, hãy chắc chắn rằng đã đọc bản hướng dẫn này để lắp đặt sản phẩm đúng cách.



Table of contents / 목차 สารบัญ / Mục lục

Safety Precautions / Precautions before installation (EN) 2	
안전상의 주의 / 설치 전의 주의 (KO) 4	
ข้อควรระวังด้านความปลอดภัย / ข้อควรระวังก่อนการติดตั้ง (TH) 6	
Chú ý về an toàn / Chú ý trước khi lắp đặt (VI) 8	
Included parts / 동봉 부품	
ชิ้นส่วนที่ให้มาด้วย / Phụ kiện đóng kèm 10	
Required items / 설치 공구	
รายการที่ต้องใช้ / Các dụng cụ cần chuẩn bị 11	
Part diagram / 완성도	
แผนผังแสดงชิ้นส่วน / Bản vẽ hoàn thiện 11	
Installation procedure / 설치 방법	
ขั้นตอนการติดตั้ง / Trình tự lắp đặt 12	
Remote control mounting (With remote control) / 리모컨 설치 (리모컨 포함 사양)	
การติดตั้งรีโมทคอนโทรล (รุ่นที่ใช้รีโมท) / Lắp điều khiển từ xa (Loại có điều khiển từ xa) 16	
Trial run / 시운전	
การทดสอบการทำงาน / Vận hành thử 17	
After trial run / 시운전 후	
หลังทดสอบการทำงาน / Sau khi vận hành thử 18	
Information for the installer / 시공업자님께 드리는 부탁 말씀	
ข้อมูลสำหรับผู้ติดตั้ง / Thông tin dành cho cửa hàng lắp đặt 18	

Safety Precautions

Be sure to carefully read this “Safety Precautions” document before beginning installation. Please comply with all safety warnings and precautions.

Symbols and Meanings

 <p>WARNING This symbol indicates misuse may result in death or serious injury.</p>	 <p>CAUTION This symbol indicates misuse may result in injury or physical damage</p>
---	--

Examples of symbols

 <p>The symbol indicates a prohibited use of the product.</p>	 <p>The symbol is used to indicate a required step in the use of this product.</p>
--	--

- This product is classified as Class I Equipment and must be grounded.
- Install this equipment where the electrical outlet is accessible.
- Use the new hose set included with this equipment. Do not reuse an old hose set.

 **WARNING**

	<p>Do not use this product with any power supply other than the one specified. (AC 220-240 V, 50 Hz/60 Hz)</p> <ul style="list-style-type: none"> • Doing so may result in heat or fire. <p>Do not use a damaged power plug, damaged power cord or loose socket outlet.</p> <ul style="list-style-type: none"> • Doing so may result in electrical shock or fire. <p>Do not install an outlet directly beneath a water supply location. Do not allow the water supply hose to touch the electrical outlet of plug.</p> <ul style="list-style-type: none"> • Condensation may seep into the outlet, resulting in fire or electrical shock. <p>Do not use other water than allowed by the laws and ordinances of the region of use. Only use drinking water. Do not use seawater or recycled water.</p> <ul style="list-style-type: none"> • Doing so may cause irritation to the skin and malfunction. <p>Do not install the product on moving vehicles such as boats or RV's.</p> <ul style="list-style-type: none"> • Doing so could cause a fire, electric shock, a short circuit, or other malfunctions. • The toilet seat, lid, product main body or other part might come loose and fall off, resulting in injury. <p>Do not do anything that could damage the power cord, power plug. Do not strike, yank, twist, excessively bend, damage, alter, or heat any power cords. Also, do not place anything heavy on, bind or pinch them.</p> <ul style="list-style-type: none"> • Using a damaged power cord may result in a fire, electrical shock, heat or a short circuit. <p>Do not exceed the rated capacity of your electrical outlets or wiring equipment.</p> <ul style="list-style-type: none"> • Using a single outlet to supply power to many devices by using an extension cord or other adapters may result in fire from excess heat.
---	--



	<p>Be sure to plug the power cord all the way into the wall socket.</p> <ul style="list-style-type: none"> • Failure to do so may result in electrical shock or fire. <p>To unplug, hold the power plug, not the power cord. Do not unplug by pulling the power cord.</p> <ul style="list-style-type: none"> • Pulling on the power cord may cause damage and result in fire or heat. <p>Make sure to waterproof the power plug by using a silicon rubber sealant.</p> <ul style="list-style-type: none"> • A power plug that has not been waterproofed may cause fire or electric shock. *If the power plug is not waterproof, ask the installer to waterproof it. <p>This is an electrical product. Do not locate it anywhere water is likely to get on it. Do not locate the product in a humid environment where water may form on the surface of the product.</p> <p>When using the product in a bathroom, install a ventilation fan or opening, so that the bathroom has sufficient airflow to avoid extreme humidity.</p> <ul style="list-style-type: none"> • Failure to do so may result in electrical shock or fire. <p>Always connect the product to the cold water supply.</p> <ul style="list-style-type: none"> • Connecting to hot water supply may result in burns and equipment damage.
---	--

Safety Precautions (Continued)

WARNING

	<p>Check that the product is electrically grounded appropriately. For a ground, use copper wire with a ground resistance of 100 Ω max. and a diameter of 1.6 mm min.</p> <ul style="list-style-type: none"> • If a ground is not installed, a breakdown or electrical current leak may result in electrical shock. *If there is no ground installed, ask the installer to put in a ground. <p>Confirm that wiring is connected correctly (L terminal: Live, N terminal: Neutral).</p> <ul style="list-style-type: none"> • Incorrect wiring may cause mechanical failure. <p>Always use a grounded (3-prong) electrical outlet and that is connected to a ground fault circuit interrupter (30mA or less).</p> <p>If the power cord is damaged, avoid danger by having the manufacturer's repair department or equivalent specialist replace it.</p> <p>When installing this product, comply with the regional codes and standards on installation work. All-pole disconnection incorporated in the fixed wiring shall be provided.</p>
---	--

CAUTION

	<p>Do not lift the product by the toilet seat or toilet lid.</p> <ul style="list-style-type: none"> • Doing so may result in the product main body dislodging, falling and causing injury. <p>Do not fold or crush the water supply hose; do not damage by cutting with a sharp object.</p> <ul style="list-style-type: none"> • Doing so may result in water leakage. <p>Do not remove the water filter drain valve while the shutoff valve is open.</p> <ul style="list-style-type: none"> • Doing so will result in water leakage.
	<p>Install the Washlet properly according to the Installation Guide.</p> <ul style="list-style-type: none"> • Improper installation may result in water leakage, electric shock or fire. <p>Push the product main body securely onto the base plate. After pushing the product main body until a click sound is heard, pull it slightly toward you to make sure that the product does not detach.</p> <ul style="list-style-type: none"> • Not doing so may result in the product main body dislodging, falling and causing injury. <p>Make sure the plus and minus signs on the batteries are aligned correctly before inserting them.*1</p> <ul style="list-style-type: none"> • Otherwise, the batteries may leak fluid, generate heat, rupture, or ignite. <p>When the product will not be used for a long time, remove the batteries from the remote control.*1</p> <ul style="list-style-type: none"> • Failure to do so may cause the batteries to leak fluid.

*1 With remote control

Precautions before installation

- Do not turn on the electricity and water supply for the product until installation work is complete.
- Do not damage the connection components on the water supply hose (C-5).
- The water supply pressure ranges from 0.05 MPa <dynamic> - 0.75 MPa <static>.
Use the unit within the said pressure range.
- The temperature of the water supply should be within a range of 0 to 35 °C. Make sure the temperature is within this range.
- Working ambient temperature is within the range of 0 to 40 °C. Make sure the temperature is within this range.
- Do not use water supply hoses (C-5) and junction valve (A-8) other than those supplied with the product.
*Because a water flow test is conducted on each product at the factory, water may remain inside the product. This water does not indicate a problem with the product.
- Perform wiring correctly according to this product's specifications (220-240 V AC (50 Hz/60 Hz)).
*Power supply, rated power consumption is indicated on the label of this product.
- The power cord is 1.2 m (For singapore, 5.0 m) long.
Check that the outlet is provided in a location appropriate for this length.

안전상의 주의

설치 전에 반드시 「안전상의 주의」를 잘 읽은 후에 안전상의 경고, 주의사항을 반드시 지켜 주십시오.

표시와 의미

경고 잘못 취급하면 사람이 사망하거나 중상을 입을 가능성이 예상되는 내용을 표시합니다.	주의 잘못 취급하면 사람이 부상을 입을 가능성 및 물적 손해의 발생이 예상되는 내용을 표시합니다.
--	--

그림 표시 예

해서는 안 되는 「금지」 내용입니다.	반드시 실행해야 하는 「강제」 내용입니다.
----------------------	-------------------------

- 이 기기는 클래스1에 속하기 때문에 접지해야 합니다.
- 이 기기는 출력 플러그에 손이 닿는 곳에 놓아 두십시오.
- 이 기기에 포함된 새로운 호스 세트를 사용하고 낡은 호스 세트는 재이용하지 마십시오.

⚠ 경고

⊘

지정된 전원(교류 220 V, 60 Hz) 이외에는 사용하지 마십시오.

- 화재나 발열이 발생할 수 있습니다.

전원 플러그 또는 전원 코드가 손상되었거나 콘센트와 연결이 느슨한 상태에서는 사용하지 마십시오.

- 화재나 감전이 발생할 수 있습니다.

급수 위치 바로 아래에 콘센트를 설치하거나 급수 호스와 전원 플러그/콘센트가 닿지 않게 하십시오.

- 결로수 등으로 인해 콘센트에 물이 들어가면 화재나 감전이 발생할 수 있습니다.

사용하는 지역의 법령 규칙에 준수하여 음용수 이외는 사용하지 마십시오.

바닷물 · 재생수도 사용하지 마십시오.

- 피부 염증을 일으키거나 기기가 고장날 수 있습니다.

차량, 선박 등 이동 수단에는 설치하지 마십시오.

- 화재나 감전, 단락, 고장이 생길 수 있습니다.
- 시트, 시트 커버, 본체 등이 분리되어 낙하하면 부상을 입을 수 있습니다.

전원 코드, 전원 플러그가 파손될 수 있는 행위는 삼가하십시오.

전원 코드를 세게 내리치지 않기, 잡아당기지 않기, 비틀지 않기, 억지로 구부리지 않기, 손상시키지 않기, 가공하지 않기, 가열하지 않기, 무거운 물건 올려놓지 않기, 묶지 않기, 틈새에 끼우지 않기.

- 손상된 상태로 사용하면 화재나 감전, 발열 및 단락이 발생할 수 있습니다.

콘센트나 배선 기구는 정격을 초과하여 사용하지 마십시오.

- 문어발 배선 등으로 정격을 초과하면 발열에 의해 화재가 발생할 수 있습니다.

!

전원 플러그는 콘센트에 확실하게 꽂으십시오.

- 화재나 감전이 발생할 수 있습니다.

전원 플러그를 뺄 때는 전원 코드가 아닌 전원 플러그를 잡으십시오.

전원 코드를 잡아당겨 전원 플러그를 빼지 마십시오.

- 전원 코드를 잡아당기면 전원 코드가 파손되어 화재 및 발열이 생길 수 있습니다.

전원 플러그가 실리콘으로 방수 처리되어 있는지 확인하십시오.

- 방수 처리하지 않으면 화재나 감전이 발생할 수 있습니다.
- ※방수 처리가 되어 있지 않은 경우에는 시공 업체에 의뢰하십시오.

본 제품은 전기 제품으므로 물이 들어가기 쉬운 장소 또는 습기가 많은 장소에는 설치하지 마십시오.

욕실 안에서 사용하는 경우에는 환풍기 또는 환기구를 설치하여 욕실 안에 공기가 잘 통하도록 하십시오.

- 화재나 감전이 발생할 수 있습니다.

제품은 반드시 냉수 공급부에 연결하십시오.

- 화상 또는 기기가 고장이 발생할 수 있습니다.

접지가 제대로 되어 있는지 확인하십시오.

접지 저항이 100 Ω 이하이며, 직경이 1.6 mm 이상인 동선을 사용하여 접지합니다.

- 접지되어 있지 않으면 고장 또는 누전 시 감전이 발생할 수 있습니다.
- ※접지가 되어 있지 않은 경우에는 시공 업체에 의뢰하십시오.

전원 코드가 바르게 접속(L극 : 라이브, N극 : 뉴트럴)되어 있는지 확인해 주십시오.

- 기기 고장의 원인이 됩니다.

안전상의 주의 (계속)

 경고



반드시 접지(3극) 전원 콘센트를 사용하여 누전 차단기(30 mA이하)에 연결하십시오.
 만일 전원 코드가 파손되었다면 위험 방지를 위해 반드시 제조사의 수리 전문가에게 의뢰하여 교환하십시오.
 본 제품을 설치할 때는 각 나라의 설치 공사 제약 조건에 따르십시오.
 전원설비측에 전원차단장치를 설치할 것.

 주의



시트 · 시트 커버를 잡고 제품을 들어올리지 마십시오.
 • 본체가 분리되어 낙하하면 부상을 입을 수 있습니다.
 급수 호스를 구부리거나 찌그러뜨리거나 커터 등으로 흠집을 내지 마십시오.
 • 누수가 발생할 수 있습니다.
 지수전을 연 채로 급수 필터, 급수 필터 배수 밸브를 분리하지 마십시오.
 • 물이 분출됩니다.



시공 설명서에 따라 확실하게 시공하십시오.
 • 바르게 설치하지 않으면 누수, 감전, 화재가 발생할 수 있습니다.
 본체는 베이스 플레이트에 확실하게 밀어 넣으십시오.
 「딸깍」 소리가 날 때까지 밀어 넣은 후, 가볍게 앞으로 잡아 당겨 본체가 분리되지 않는지 확인하십시오.
 • 본체가 분리되어 낙하하면 부상을 입을 수 있습니다.
 건전지의 +, - 표시를 확인하여 넣습니다.^{※1}
 • 건전지 누액이나 발열 및 파열손으로 화재의 원인이 됩니다.
 장기간 사용하지 않을 때는 리모컨 또는 건전지박스에서 건전지를 분리하여 주십시오.^{※1}
 • 건전지 누액이 나오는 원인이 됩니다.

※1 리모컨 포함 사양

설치 전의 주의

- 제품에 통전 및 통수는 설치작업을 모두 끝낸 후에 해 주십시오.
- 급수호스(C-5)의 선단 접속부에 상처가 나지 않도록 주의해 주십시오.
- 급수압력 범위는 0.05 MPa<유동 시>~0.75 MPa<정지시>입니다.
 이 압력 범위에서 장치를 사용해 주십시오.
- 급수온도는 0~35 °C 입니다. 이 온도범위에서 사용해 주십시오.
- 주위 사용 온도는 0~40 °C 입니다. 이 온도범위에서 사용해 주십시오.
- 동봉된 급수호스(C-5)와 연결밸브(A-8) 외에는 사용하지 말아 주십시오.
 ※출하 전에 통수 검사를 하기 때문에 제품 안에 물이 남아 있는 경우가 있으나, 제품에는 문제가 없습니다.
- 본 제품의 사양(교류220 V (60 Hz))에 적합한 배선을 사용 해 주십시오.
 ※전원 공급, 정격 소비전력은 본 제품 라벨에 표시되어 있습니다.
- 전원 코드의 길이는 1.8 m입니다.
 콘센트가 전원 코드 길이에 적합한 위치에 있는지 확인하십시오.



ข้อควรระวังด้านความปลอดภัย

กรุณาอ่าน "ข้อควรระวังเพื่อความปลอดภัย" นี้อย่างละเอียดก่อนการติดตั้งรวมถึงปฏิบัติตามคำแนะนำและข้อควรระวังเพื่อความปลอดภัย

สัญลักษณ์และความหมาย

 คำเตือน	สัญลักษณ์นี้บ่งชี้ว่าการใช้งานผิดอาจทำให้เกิดการบาดเจ็บร้ายแรงหรือถึงแก่ความตายได้	 ข้อควรระวัง	สัญลักษณ์นี้บ่งชี้ว่าการใช้งานผิดอาจทำให้เกิดการบาดเจ็บหรือผลิตภัณฑ์เกิดความเสียหายทางกายภาพได้
--	--	--	---

ตัวอย่างสัญลักษณ์

 สัญลักษณ์นี้บ่งชี้ว่าเป็นข้อห้ามสำหรับผลิตภัณฑ์	 ใช้สัญลักษณ์นี้เพื่อแสดงขั้นตอนที่จำเป็นในการใช้ผลิตภัณฑ์นี้
---	--

- ผลิตภัณฑ์นี้ถูกจัดเป็นอุปกรณ์ประเภท I และต้องมีการต่อสายดิน
- ติดตั้งผลิตภัณฑ์นี้ในบริเวณที่สามารถเข้าถึงเต้าเสียบสายไฟได้
- ใช้สายยางชุดใหม่ที่จัดส่งไปให้พร้อมกับผลิตภัณฑ์ ห้ามนำสายยางชุดเก่ากลับมาใช้

 คำเตือน



	<p>อย่าต่อผลิตภัณฑ์นี้เข้ากับแหล่งจ่ายไฟแบบอื่นนอกเหนือจากที่ระบุไว้ (AC 220-240 V, 50 Hz/60 Hz)</p> <ul style="list-style-type: none"> • มิฉะนั้น อาจทำให้เกิดความร้อนสูง หรือไฟไหม้ได้ <p>อย่าใช้ปลั๊กไฟ/สายไฟที่เสียหาย หรือเต้าเสียบที่หลวม</p> <ul style="list-style-type: none"> • มิฉะนั้น อาจทำให้เกิดไฟฟ้าช็อตหรือไฟไหม้ได้ <p>อย่าติดตั้งเต้าเสียบสายไฟใต้ตำแหน่งที่จ่ายน้ำโดยตรง อย่าให้สายยางจ่ายน้ำสัมผัสกับเต้าเสียบปลั๊กไฟ</p> <ul style="list-style-type: none"> • ความชื้นหรือไอน้ำอาจแทรกเข้าไปในเต้าเสียบและทำให้เกิดไฟฟ้าช็อตหรือไฟไหม้ได้ <p>อย่าใช้น้ำอื่น ๆ นอกจากที่อนุญาตให้ใช้ได้ตามข้อกำหนดของกฎหมายและสอดคล้องกับขอบเขตการใช้งาน โปรดใช้น้ำดื่มเท่านั้น</p> <p>อย่าใช้น้ำทะเล หรือน้ำที่นำกลับมาใช้ใหม่</p> <ul style="list-style-type: none"> • การทำเช่นนั้นจะทำให้เกิดการระคายเคืองต่อผิวหนังและทำงานผิดปกติได้ <p>อย่าติดตั้งผลิตภัณฑ์ในยานพาหนะที่เคลื่อนที่ได้ เช่น ในเรือหรือรถ RV</p> <ul style="list-style-type: none"> • มิฉะนั้น อาจทำให้เกิดไฟไหม้, ไฟฟ้าช็อต, ไฟลัดวงจร หรือความผิดปกติอื่น ๆ • ที่นั่ง, ฝาโถ, ตัวสุขภัณฑ์ หรือชิ้นส่วนอื่นๆ อาจหลวมและหลุดออกมา ทำให้เกิดการบาดเจ็บได้ <p>อย่าทำการใดๆ ที่อาจทำให้สายไฟ, ปลั๊กไฟเสียหาย</p> <p>อย่าทุบ, ทุบ, บิด หรือออสายไฟมากเกินไป, ทำความเสียหาย, ปรับเปลี่ยน หรือทำให้สายไฟร้อน</p> <p>ห้ามวางของหนักทับบนสายไฟ, ผูก หรือหนีบสายไฟ</p> <ul style="list-style-type: none"> • การใช้สายไฟที่เสียหายอาจทำให้เกิดไฟไหม้, ไฟฟ้าช็อต, เกิดความร้อน หรือไฟลัดวงจร <p>อย่าใช้เต้าเสียบหรือสายไฟเกินกว่าพิกัดไฟฟ้าที่ได้รับ</p> <ul style="list-style-type: none"> • การใช้เต้าเสียบปลั๊กอันเดียวเพื่อจ่ายไฟให้กับอุปกรณ์หลายๆ ชิ้น โดยใช้หัวต่อหรือแอดแดปเตอร์แบบอื่นๆ อาจทำให้เกิดไฟไหม้จากความร้อนที่สูงเกิน
	<p>ตรวจสอบให้แน่ใจว่าเสียบสายไฟเข้าไปในเต้าเสียบที่ผนังจนสุด</p> <ul style="list-style-type: none"> • มิฉะนั้น อาจทำให้เกิดไฟฟ้าช็อตหรือไฟไหม้ได้ <p>เมื่อดึงปลั๊กออก ให้จับที่ตัวปลั๊ก ไม่ใช่ที่สายไฟ</p> <p>อย่าดึงปลั๊กออกโดยดึงสายไฟ</p> <ul style="list-style-type: none"> • การดึงที่สายไฟอาจทำให้เกิดความเสียหาย และเกิดไฟไหม้หรือความร้อนได้ <p>ตรวจสอบให้แน่ใจว่าได้ใช้ยางซิลิโคนซีลปิดปลั๊กไฟไว้ เพื่อให้สามารถกันน้ำได้</p> <ul style="list-style-type: none"> • ปลั๊กไฟที่ยังไม่ได้ซีลให้สามารถกันน้ำได้ อาจทำให้เกิดไฟไหม้หรือไฟฟ้าช็อตได้ * หากปลั๊กไฟไม่สามารถกันน้ำได้ ให้ขอให้ผู้ติดตั้งซีลกันน้ำที่ปลั๊กไฟให้ <p>ผลิตภัณฑ์นี้เป็นผลิตภัณฑ์ไฟฟ้า อย่าวางผลิตภัณฑ์ไว้ในบริเวณที่อาจสัมผัสน้ำ อย่าวางผลิตภัณฑ์ไว้ในสภาพแวดล้อมที่มีความชื้นสูง เพราะอาจทำให้มีหยดน้ำก่อตัวขึ้นบนผลิตภัณฑ์</p> <p>เมื่อใช้ผลิตภัณฑ์ในห้องสุขา ให้ติดตั้งพัดลมหรือช่องระบายอากาศ เพื่อให้ห้องสุขามีอากาศหมุนเวียนอย่างเพียงพอและป้องกันไม่ให้เกิดความชื้นมากเกินไป</p> <ul style="list-style-type: none"> • มิฉะนั้น อาจทำให้เกิดไฟฟ้าช็อตหรือไฟไหม้ได้ <p>ต่อผลิตภัณฑ์เข้ากับหัวจ่ายน้ำเย็นเท่านั้น</p> <ul style="list-style-type: none"> * การต่อเข้ากับหัวจ่ายน้ำร้อนอาจทำให้เกิดการไหม้ และอุปกรณ์เสียหายได้

ข้อควรระวังด้านความปลอดภัย (ต่อ)

⚠ คำเตือน

	<p>ตรวจสอบว่ามีการติดตั้งสายดินอย่างถูกต้อง ใช้สายทองแดงที่มีความต้านทานสูงสุด 100 Ω และมีเส้นผ่านศูนย์กลางไม่ต่ำกว่า 1.6 มม. เป็นสายดิน</p> <ul style="list-style-type: none"> • หากยังไม่ได้ทำการต่อสายดิน อาจเกิดไฟฟ้าช็อตเมื่อมีกระแสไฟรั่วหรือเมื่อผลิตภัณฑ์เสีย * หากยังไม่ได้ทำการต่อสายดิน ให้ขอให้ผู้ติดตั้งต่อสายดินให้ <p>ตรวจสอบให้แน่ใจว่ามีการเชื่อมต่อสายไฟอย่างถูกต้องแล้ว (ขั้ว L : มีกระแสไฟฟ้าไหลผ่าน, ขั้ว N : เป็นกลาง).</p> <ul style="list-style-type: none"> • การเดินสายไฟที่ไม่ถูกต้องอาจทำให้เกิดความขัดข้องเชิงกลได้ <p>ใช้เต้าเสียบที่มีขั้วสายดิน (แบบ 3 ขา) และต้องเชื่อมต่อเข้ากับ เครื่องตัดวงจรไฟฟ้าเมื่อกระแสรั่วลงดิน (Ground Fault Circuit Interrupter) ขนาด 30 มิลลิแอมแปร์หรือน้อยกว่า</p> <p>หากสายไฟเสียหาย ต้องให้แผนกบริการซ่อมของผู้ผลิตหรือผู้ที่มีความชำนาญเทียบเท่ากันทำการเปลี่ยนสายไฟให้ใหม่ เพื่อป้องกันอันตรายที่อาจเกิดขึ้นได้</p> <p>เมื่อติดตั้งผลิตภัณฑ์นี้ ให้ปฏิบัติตามกฎและมาตรฐานสำหรับงานติดตั้งต้องทำการเก็บสายไฟให้เป็นระเบียบและยึดอยู่กับที่</p>
---	--

⚠ ข้อควรระวัง

	<p>อย่ากดผลิตภัณฑ์โดยจับที่ที่นั่งหรือฝาปิดโถสุขภัณฑ์</p> <ul style="list-style-type: none"> • มิฉะนั้น อาจทำให้ชิ้นส่วนหลักของผลิตภัณฑ์หลุดออกมา, หล่น และทำให้เกิดการบาดเจ็บได้ <p>อย่าพับหรือบิดขยี้สายยางหรือท่อน้ำ อย่าใช้วัตถุแหลมคมตัดหรือแทงสายให้เกิดความเสียหาย</p> <ul style="list-style-type: none"> • มิฉะนั้น อาจทำให้มีน้ำรั่วได้ <p>อย่าถอดตัวกรองของวาล์วระบายน้ำออก ขณะที่วาล์วควบคุมน้ำเปิดอยู่</p> <ul style="list-style-type: none"> • มิฉะนั้น จะทำให้มีน้ำรั่วได้
	<p>ติดตั้ง Washlet ให้ถูกต้องตามคำแนะนำในการติดตั้ง</p> <ul style="list-style-type: none"> • การติดตั้งที่ไม่ถูกต้องอาจทำให้มีน้ำรั่ว, เกิดไฟฟ้าช็อตหรือไฟไหม้ได้ <p>ประกอบผลิตภัณฑ์เข้ากับฐาน (Base plate) ให้แน่น</p> <p>โดยหลังจากประกอบเข้าแล้วจะมีเสียงคลิก ให้ทดลองดึงผลิตภัณฑ์เข้าหาตัวผู้ติดตั้ง</p> <p>เพื่อให้แน่ใจว่า ผลิตภัณฑ์จะไม่หลุดออก</p> <ul style="list-style-type: none"> • การไม่ทำเช่นนี้อาจทำให้ชิ้นส่วนหลักของผลิตภัณฑ์หลุดออกมา, หล่น และทำให้เกิดการบาดเจ็บได้ <p>ตรวจสอบเครื่องหมาย +/- บนแบตเตอรี่ให้เรียบร้อยก่อนใส่*1</p> <ul style="list-style-type: none"> • เพราะอาจเป็นสาเหตุให้ของเหลวในแบตเตอรี่รั่วซึม เกิดความร้อน แดงหรือเกิดเปลวไฟ <p>เมื่อไม่ใช้งานเป็นเวลานาน ให้เอาแบตเตอรี่ออกจากรีโมทคอนโทรล*1</p> <ul style="list-style-type: none"> • เพราะอาจเป็นสาเหตุให้ของเหลวในแบตเตอรี่รั่วซึมได้

*1 รุ่นที่ใช้รีโมท



ข้อควรระวังก่อนการติดตั้ง

- ห้ามจ่ายไฟฟ้าและน้ำเข้าผลิตภัณฑ์จนกว่าจะติดตั้งแล้วเสร็จสมบูรณ์
- อย่าทำให้ชิ้นส่วนสำหรับต่อสายยางจ่ายน้ำ (C-5) เสียหาย
- ขอบเขตแรงดันน้ำที่จ่ายออก 0.05 MPa <ไดนามิก> -0.75 MPa <คงที่> ใช้งานชุดผลิตภัณฑ์ในช่วงแรงดันที่กำหนดไว้
- อุณหภูมิของน้ำที่จ่ายต้องอยู่ในช่วง 0 ถึง 35 °C ตรวจสอบให้แน่ใจว่าอุณหภูมิมีค่าอยู่ในช่วงดังกล่าว
- อุณหภูมิของสภาวะแวดล้อมโดยรอบในการทำงานต้องอยู่ในช่วง 0 ถึง 40 °C ตรวจสอบให้แน่ใจว่าอุณหภูมิมีค่าอยู่ในช่วงดังกล่าว
- อย่าใช้ท่อน้ำ (C-5) และวาล์วน้ำ (A-8) ที่ไม่ได้ให้มากับผลิตภัณฑ์
 - * ผลิตภัณฑ์อาจมีน้ำค้างอยู่ภายในเนื่องจากผลิตภัณฑ์แต่ละชิ้นจะต้องผ่านการทดสอบการไหลของน้ำ ณ โรงงานผลิต น้ำที่ค้างอยู่นี้ไม่ได้บ่งชี้ว่าผลิตภัณฑ์มีปัญหา
- กรณาดำเนินสายไฟตามข้อกำหนดของผลิตภัณฑ์นี้ (AC 220-240 V (50 Hz / 60 Hz))
 - * แหล่งจ่ายไฟและกำลังไฟที่ใช้จะระบุอยู่บนฉลากของผลิตภัณฑ์นี้
- ความยาวสายไฟ 1.2 ม.
ตรวจสอบว่าเต้ารับอยู่ในตำแหน่งที่เหมาะสมกับความยาวนี้



Chú ý về an toàn

Trước khi lắp đặt, hãy chắc chắn rằng đã đọc chú ý về an toàn này để có thể tuân theo đúng các hạng mục chú ý, cảnh báo về an toàn.

Biểu tượng và ý nghĩa



 Cảnh báo	Biểu tượng này hiển thị rằng nếu sử dụng không đúng cách thì sẽ có nguy cơ gây ra tử vong hoặc gây thương tích nghiêm trọng cho người sử dụng.	 Chú ý	Biểu tượng này hiển thị rằng nếu sử dụng không đúng cách thì sẽ có nguy cơ gây ra thiệt hại về tài sản và thương tích cho người sử dụng.
---	--	--	--

Ví dụ về biểu tượng

 Là nội dung “Cấm”, không được thực hiện.	 Là nội dung “Bắt buộc”, cần phải thực hiện.
--	---

- Sản phẩm được phân loại trong nhóm Thiết bị Loại I và phải được nối đất.
- Hãy đặt sản phẩm này ở nơi có sẵn ổ cắm điện.
- Sử dụng bộ vòi mới đi kèm với thiết bị này. Không sử dụng lại bộ vòi cũ.

Cảnh báo



	<p>Không sử dụng nguồn điện khác với nguồn điện chỉ định. (AC 220-240 V, 50 Hz/60 Hz)</p> <ul style="list-style-type: none"> • Do có thể gây ra chập điện, cháy nổ. <p>Không sử dụng dây điện, phích cắm nguồn điện bị trầy xước, và ổ cắm lỏng lẻo.</p> <ul style="list-style-type: none"> • nếu không, có thể sẽ gây ra cháy nổ, điện giật. <p>Không lắp ổ cắm điện ở phía dưới vị trí cấp nước, không để dây cấp nước tiếp xúc với phích cắm và ổ cắm điện.</p> <ul style="list-style-type: none"> • nếu không, ổ cắm điện có thể bị ngấm nước do hơi nước ngưng tụ sẽ gây ra cháy nổ, điện giật <p>Không dùng loại nước khác ngoài loại được cho phép theo luật lệ và quy định của khu vực sử dụng. Chỉ Dùng nước uống.</p> <p>Không sử dụng nước biển hoặc nước tái chế.</p> <ul style="list-style-type: none"> • Do có thể gây kích ứng cho da và trực tràng. <p>Không lắp đặt trên các phương tiện chuyển động như xe cộ, tàu thuyền...</p> <ul style="list-style-type: none"> • nếu không, có thể gây ra các sự cố cháy nổ, điện giật, chập điện. • hoặc bệ ngồi, nắp đậy hoặc thân sản phẩm có thể bị lỏng, bung ra, rơi xuống gây bị thương cho con người. <p>Không làm bất cứ điều gì gây hư hại cho phích cắm và dây điện</p> <p>Đối với dây nguồn thì không được đập, kéo căng, xoắn, cố uốn, làm xước, gia công, làm nóng dây, không đặt vật nặng đè lên dây, buộc hay gài bất cứ thứ gì vào dây.</p> <ul style="list-style-type: none"> • nếu dây bị trầy xước mà cứ để nguyên như vậy sử dụng thì có thể sẽ gây ra cháy nổ, điện giật, sinh nhiệt, chập điện. <p>Không sử dụng vượt quá tải quy định của ổ cắm và dây dẫn.</p> <ul style="list-style-type: none"> • nếu vượt quá định mức cho phép, ví dụ như dùng một ổ cắm nguồn mà cắm dùng cho quá nhiều thiết bị bằng cách cắm thêm ổ cắm chia thì có thể sẽ phát nhiệt dẫn đến hỏa hoạn.
	<p>Hãy chắc chắn rằng các phích cắm đã được cắm chắc chắn vào ổ cắm điện.</p> <ul style="list-style-type: none"> • nếu không, có thể sẽ gây ra cháy nổ, điện giật. <p>Khi tháo phích cắm thì cầm vào phích cắm chứ không cầm vào dây.</p> <p>Không được tháo bằng cách kéo dây.</p> <ul style="list-style-type: none"> • Nếu kéo căng dây có thể sẽ làm hỏng hóc dẫn đến cháy nổ, phát nhiệt. <p>Hãy xác nhận rằng phích cắm điện đã được xử lý chống thấm nước bằng cao su silicone.</p> <ul style="list-style-type: none"> • nếu không tiến hành xử lý chống thấm nước thì có thể sẽ gây ra cháy nổ, điện giật. <p>*Trường hợp phích cắm không được xử lý chống thấm nước, hãy liên hệ đến cửa hàng đã lắp đặt để được xử lý.</p> <p>Sản phẩm này là đồ điện tử nên không được lắp đặt ở những vị trí dễ bị nước ngấm vào hoặc nơi có độ ẩm lớn để tạo giọt nước bám vào bề mặt sản phẩm. Trường hợp sử dụng ở trong phòng tắm thì hãy lắp quạt thông gió hoặc tạo lỗ thông gió để không khí có thể lưu thông bên trong phòng tắm.</p> <ul style="list-style-type: none"> • nếu không, có thể sẽ gây ra cháy nổ, điện giật.

Chú ý về an toàn (Tiếp tục)

Cảnh báo

	<p>Luôn kết nối sản phẩm với nguồn nước lạnh.</p> <ul style="list-style-type: none"> • nếu kết nối với nguồn nước nóng thì có nguy cơ gây bỏng, hoặc là gây hỏng hóc thiết bị. <p>Hãy xác nhận rằng sản phẩm được nối đất một cách hợp lý.</p> <p>Điện trở nối đất phải $\leq 100 \Omega$, sử dụng đường kính dây đồng $\geq 1.6 \text{ mm}$.</p> <ul style="list-style-type: none"> • nếu không nối đất, có thể sẽ là dẫn đến bị điện giật khi có sự rò rỉ điện và sự cố xảy ra. *Khi không được nối đất, hãy liên hệ yêu cầu đến cửa hàng đã lắp đặt để được xử lý. <p>Xác nhận hệ thống điện được lắp đúng (Cực L: dương, Cực N: trung tính).</p> <ul style="list-style-type: none"> • Hệ thống điện sai có thể dẫn đến thiết bị không hoạt động. <p>Luôn luôn sử dụng ổ cắm điện nối đất (3 chạc) và nó phải được nối với át tô mát nối đất (30 mA trở xuống)</p> <p>Nếu dây điện bị hỏng hóc, để tránh nguy hiểm, hãy trao đổi với nhân viên có chuyên môn hoặc bên sửa chữa của nhà cung cấp để được thay thế.</p> <p>Khi lắp đặt sản phẩm này, hãy tuân thủ theo các quy định về lắp đặt của từng quốc gia.</p> <p>Phải lắp đặt toàn bộ át tô mát cho các dây cố định.</p>
---	--

Chú ý

	<p>Không nhấc sản phẩm lên bằng cách nắm vào nắp hoặc bộ ngồi.</p> <ul style="list-style-type: none"> • Nếu không, phần thân sản phẩm bị tuột, rơi ra có thể sẽ gây ra thương tích. <p>Không bẻ gập, làm bẹp dây cáp nước hay làm hỏng dây bằng các vật sắc nhọn.</p> <ul style="list-style-type: none"> • Nếu không, có thể sẽ gây ra rò nước. <p>Không được tháo lọc nước kiêm nút bịt khi van dừng vẫn còn đang ở trạng thái mở</p> <ul style="list-style-type: none"> • Nếu không, có thể sẽ dẫn đến rò rỉ nước.
	<p>Phải lắp đặt tuân thủ theo sách hướng dẫn lắp đặt.</p> <ul style="list-style-type: none"> • nếu lắp không đúng, có thể sẽ gây ra rò nước, điện giật, cháy nổ. <p>Phần thân sản phẩm phải được lắp chắc chắn vào giá.</p> <p>Sau khi ấn sản phẩm đến khi có âm thanh "cạch", hãy kéo nhẹ phần thân về phía trước rồi xác nhận chắc chắn rằng nó không bị tuột ra.</p> <ul style="list-style-type: none"> • Nếu không, phần thân sản phẩm nếu bị tuột ra sẽ là dẫn đến bị thương. <p>Đảm bảo kí hiệu âm và dương trên pin trước khi lắp chúng.*1</p> <ul style="list-style-type: none"> • Nếu không, pin có thể bị rò rỉ chất lỏng, tạo ra nhiệt, vỡ hoặc cháy. <p>Nếu không sử dụng sản phẩm trong một thời gian dài, hãy tháo pin ở trong điều khiển từ xa.*1</p> <ul style="list-style-type: none"> • Nếu không pin có thể bị rò rỉ chất lỏng.

*1 Loại có điều khiển từ xa

Chú ý trước khi lắp đặt

- Không tiến hành cấp điện và nước cho đến khi hoàn tất toàn bộ các khâu lắp đặt.
- Không làm hỏng khớp nối của dây cáp nước (C-5)
- Áp suất cấp nước từ 0.05 MPa [ở trạng thái động] đến 0.75 MPa [ở trạng thái tĩnh].
Sử dụng thiết bị trong phạm vi áp suất nói trên.
- Nhiệt độ cấp nước là 0-35 °C, chắc chắn phải sử dụng trong phạm vi nhiệt độ này.
- Nhiệt độ sử dụng xung quanh là 0-40 °C, chắc chắn phải sử dụng trong phạm vi nhiệt độ này.
- Không sử dụng ống cấp nước (C-5) và van nối (A-8) khác với những loại được cung cấp kèm theo sản phẩm.
*Do kiểm tra thông nước trước khi xuất hàng, nên sẽ có trường hợp còn đọng nước bên trong sản phẩm tuy nhiên, điều này không có vấn đề gì đối với sản phẩm.
- Hãy đi dây phù hợp với thông số kỹ thuật của sản phẩm này (công suất định mức lớn hơn hoặc bằng 10 A, AC 220-240V (50 Hz / 60 Hz)).
*Nguồn cấp điện, công suất định mức được ghi trên nhãn của sản phẩm này.
- Dây nguồn dài 1,2 m.
Kiểm tra xem ổ cắm có được đặt ở vị trí thích hợp với chiều dài này không.

Included parts / 동봉 부품 / ชิ้นส่วนที่นำมาด้วย / Phụ kiện đóng kèm.

With remote control / 리모컨 포함 사양 / รุ่นที่ใช้รีโมท / Loại có điều khiển từ xa

A-1



A-2



A-3



A-4



A-5



Anti-theft parts for remote control

리모컨 도난 방지 키트

ชิ้นส่วนป้องกันการลักขโมยสำหรับรีโมทคอนโทรล

Phụ kiện chống trộm của điều khiển từ xa.

A-6



A-7

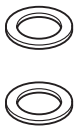

A-8

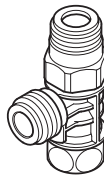

A-9

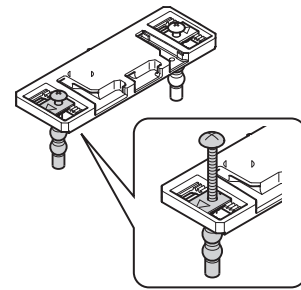

A-10



A-11

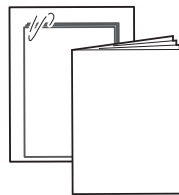

A-12

With remote control
리모컨 포함 사양

รุ่นที่ใช้รีโมท

Loại có điều khiển từ xa



A-6, A-12





*Please ask home owner if they would like anti-theft parts for remote control (A-6) and a remote control operation guide (A-12) installed before starting installation. Please leave the anti-theft kit with the owner if it is not installed.

*리모컨 도난 방지용 부품(A-6)과 표시 패널 구성품(A-12)은 반드시 고객의 요구를 들은 후 작업해 주십시오. 사용하지 않는 경우에는 반드시 고객에게 전달해 주십시오.

*กรุณาสอบถามลูกค้าว่าต้องการชิ้นส่วนที่มีโปรแกรมป้องกันการขโมยสำหรับรีโมทคอนโทรล (A-6) และคำแนะนำการใช้ งาน (A-12) ซึ่งมีการติดตั้งไว้แล้วหรือไม่ ก่อนเริ่มการติดตั้ง

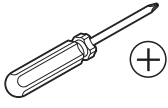
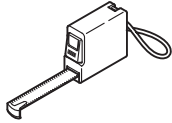
*Trước khi thao tác lắp đặt hãy hỏi chủ nhà xem có mong muốn lắp đặt phụ kiện chống trộm của bảng điều khiển từ xa (A-6) và hướng dẫn vận hành điều khiển từ xa (A-14). Nếu không lắp đặt, hãy để chủ nhà giữ bộ chống trộm.

Required items / 설치 공구 / รายการที่ต้องใช้ / Các dụng cụ cần chuẩn bị

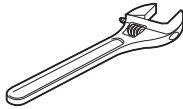
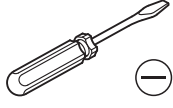
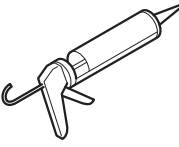
<p>B-1</p> 	<p>B-2</p> 	<p>B-3</p> 	<p>B-4</p>  <p>Use B-4 to prevent damage to the product. 제품에 흠집이 생기지 않도록 주의하여 사용해 주십시오. ใช้ B-4 เพื่อป้องกันไม่ให้ผลิตภัณฑ์เสียหาย Sử dụng B-4 để tránh gây hỏng sản phẩm</p>
<p>B-5</p> <p>With remote control / 리모컨 포함 사양 รุ่นที่ใช้รีโมท / Loại có điều khiển từ xa</p> 	<p>B-6</p>  <p>×2</p>	<p>B-7</p> 	<p>B-8</p> 

Part diagram / 완성도 / แผนผังแสดงชิ้นส่วน / Bản vẽ hoàn thiện

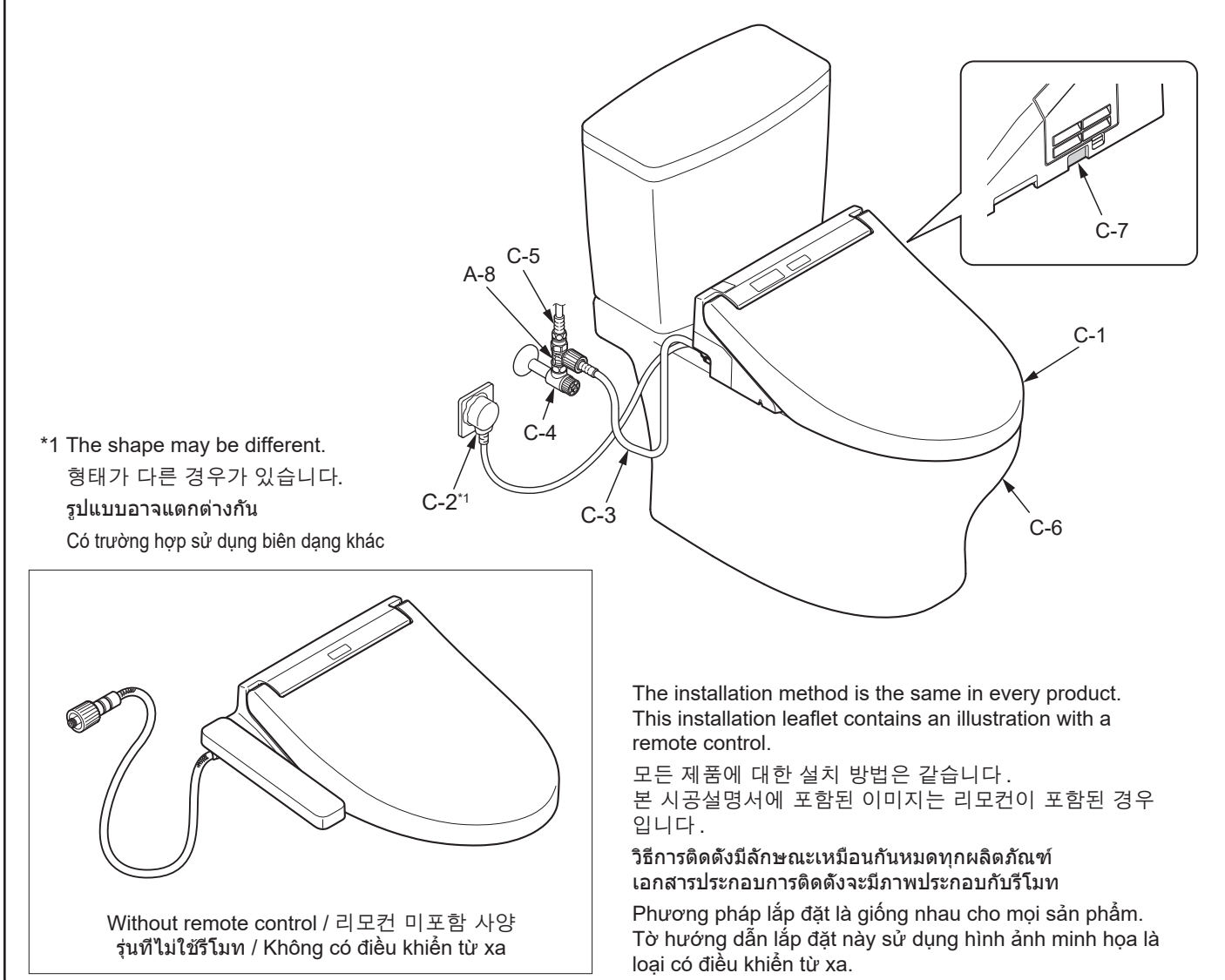

Symbols and their meanings / 표시 의미 / สัญลักษณ์และความหมาย / Ý nghĩa của biểu tượng

 Tasks that must be conducted by the installer.
 시공자가 반드시 해야 하는 작업입니다.
 งานที่ผู้ติดตั้งต้องทำ
 Là thao tác phải được thực hiện bởi thợ lắp đặt.



 Work flow direction.
 작업 순서를 나타냅니다.
 ขั้นตอนการทำงาน
 Hiện thị thứ tự của thao tác.

 Actions that the product should perform automatically.
 제품이 자동적으로 실시하는 작업입니다.
 สิ่งที่ผลิตภัณฑ์ควรทำโดยอัตโนมัติ
 Các thao tác trên sản phẩm phải được thực hiện tự động.

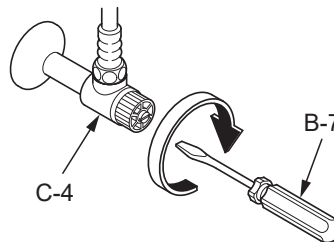

 Visual confirmation required.
 반드시 확인해야 하는 작업입니다.
 ต้องทำการตรวจสอบ
 Thao tác này cần phải kiểm tra bằng mắt.

Installation procedure / 설치 방법 / ขั้นตอนการติดตั้ง / Trình tự lắp đặt

1 Close the water shutoff valve (C-4).
 지수전 밸브(C-4)를 닫는다.
 ปิดวาล์วปิดน้ำ (C-4)
 Đóng van dừng nước (C-4).

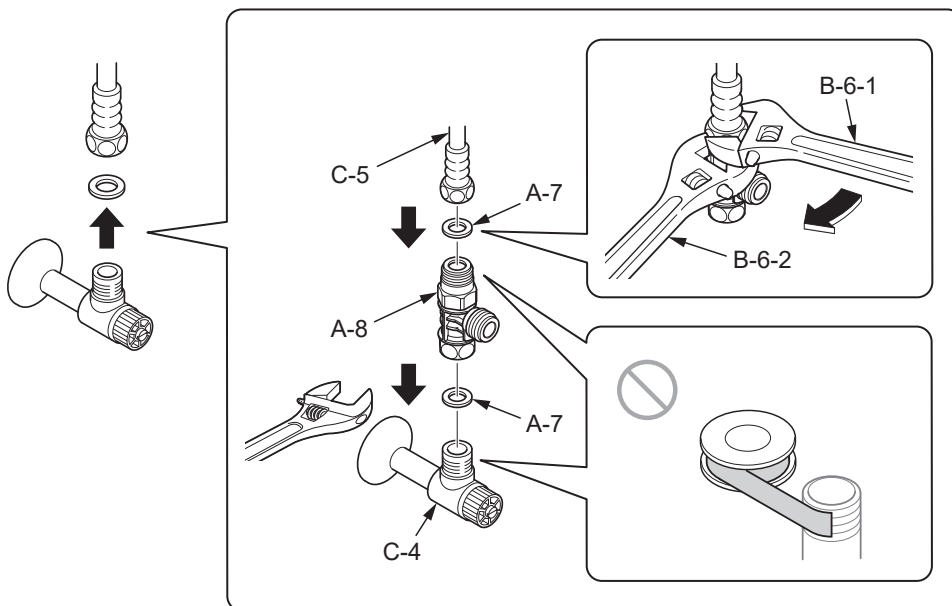

2



3

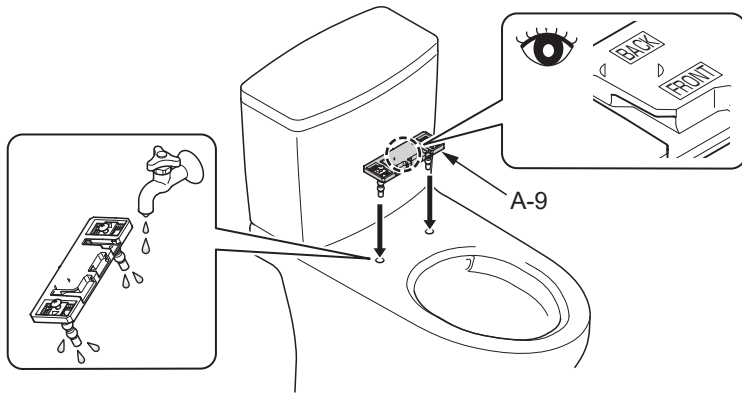

4

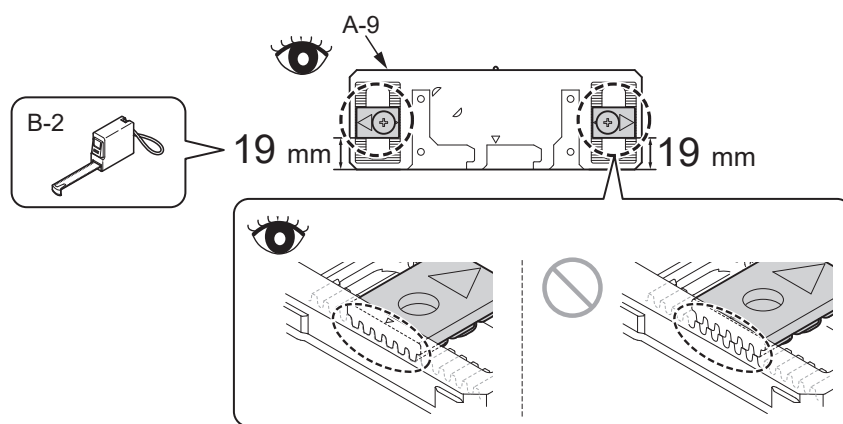

5

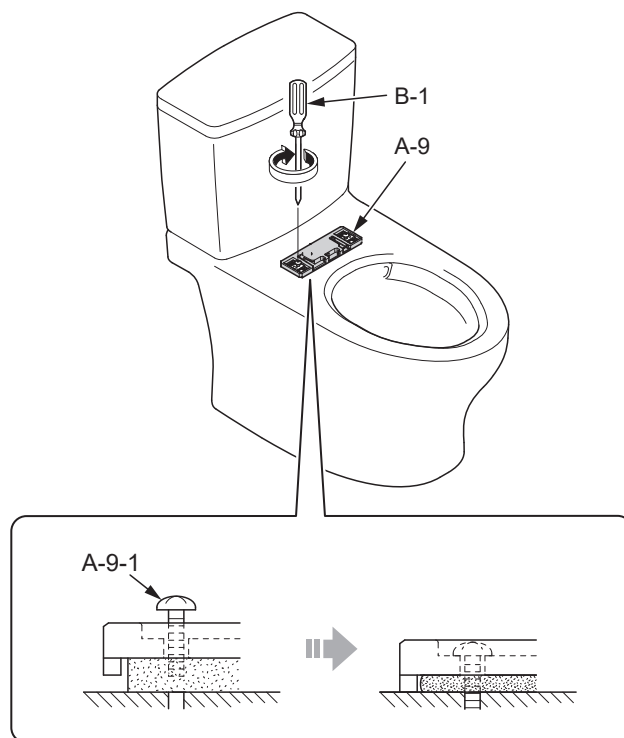

Failure to tighten screw A-9-1 completely will cause moving sideways of C-1.
 A-9-1을 확실히 고정하지 않으면, C-1이 좌우로 흔들리는 원인이됩니다.
 หากไม่ขันสกรู A-9-1 ให้เรียบร้อยจะทำให้ C-1 เคลื่อนไปด้านข้างได้
 Việc không siết chặt vít A-9-1 hết mức sẽ khiến C-1 dịch chuyển.

6 Insert C-1 into A-9 until a click sound is heard.
 (After C-1 is mounted, make sure that it can not be removed even if it is pulled.)

딸깍하는 소리가 날 때까지 C-1을 A-9에 삽입한다.
 (설치 후 C-1을 잡아당겨도 빠지지 않는지 확인하십시오.)

ใส่ C-1 ลงใน A-9 จนกระทั่งได้ยินเสียงคลิก
 (หลังจากที่ยึด C-1 แล้ว ต้องตรวจสอบให้แน่ใจว่าไม่สามารถ
 ถอดชิ้นส่วนนี้ออกได้แม้ว่าจะพยายามดึงออกก็ตาม)

Cắm C-1 vào A-9 cho đến khi có âm thanh “cách”
 (sau khi lắp đặt, hãy xác nhận rằng cho dù có kéo
 căng C-1 ra cũng không bị tuột ra).

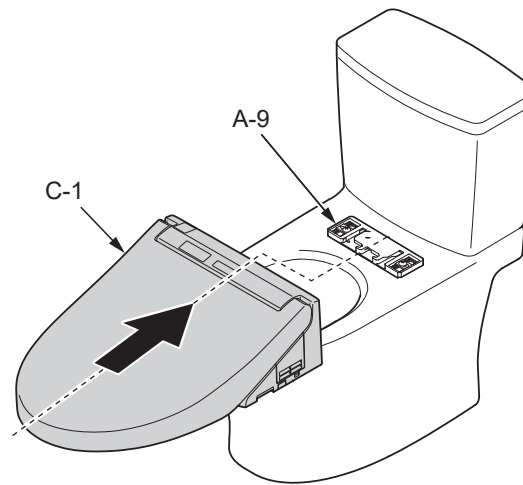

7

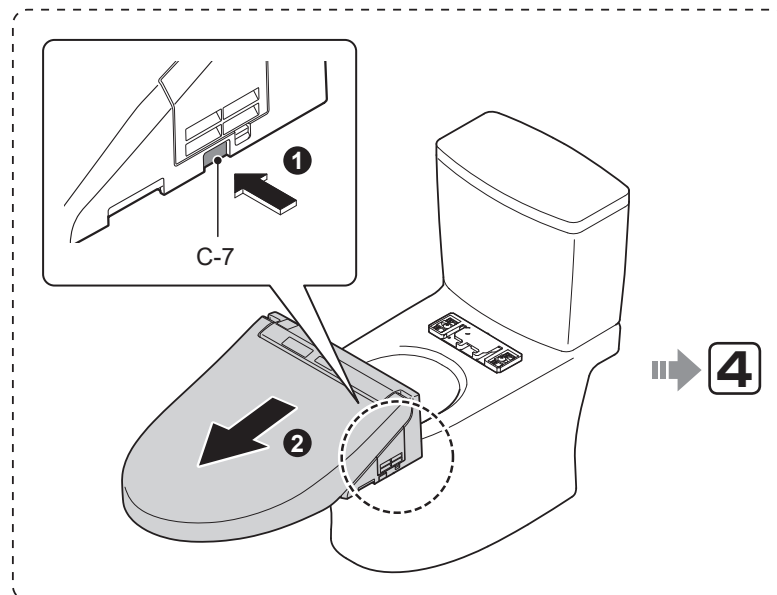
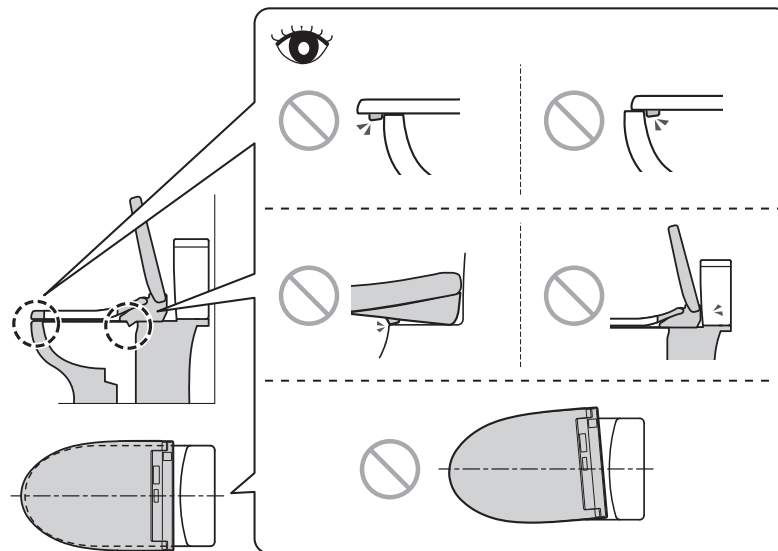

8

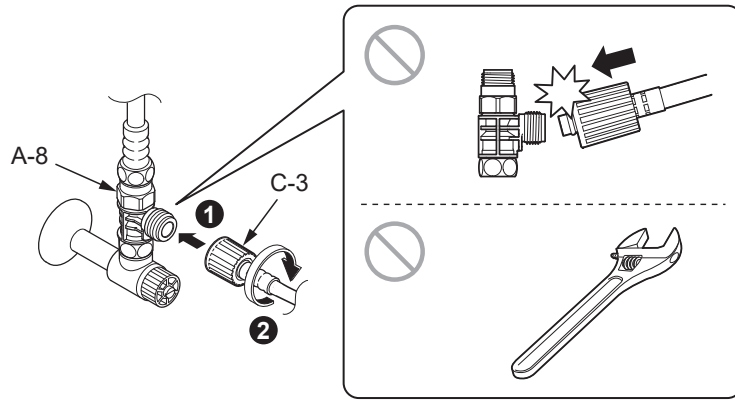

9

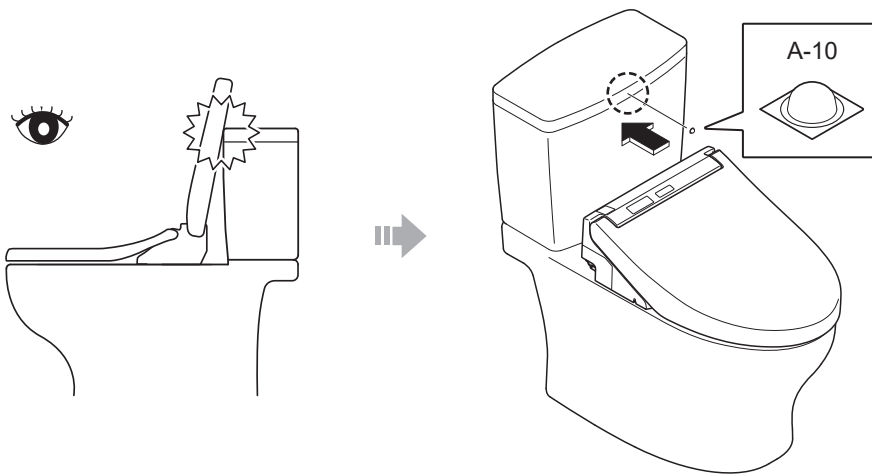

10

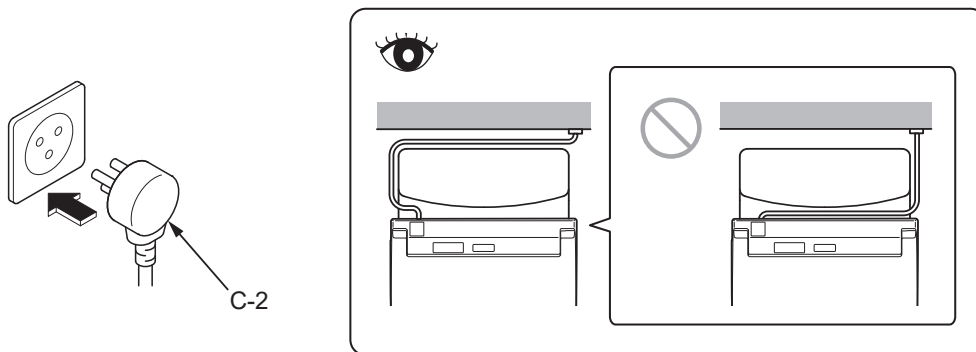

Remote control mounting / 리모컨 설치 / การติดตั้งรีโมทคอนโทรล / Lắp điều khiển từ xa

11

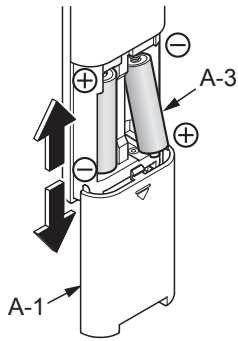

12

Side wall / 측벽 / ผนังด้านข้าง / Tường ngang.

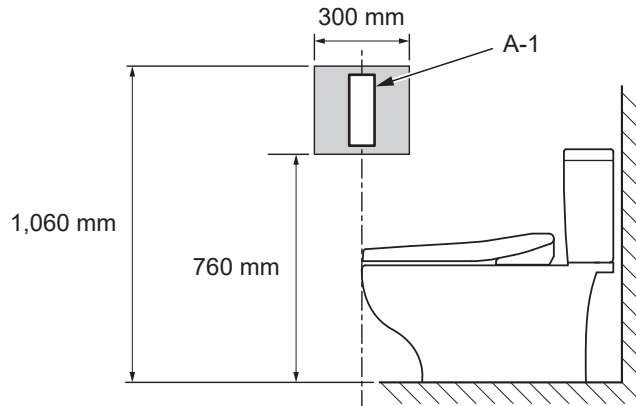

13

Temporarily place the remote control in the position determined in 12 and confirm the signal reception of A-1.

12 에서 정한 임의 위치에서, A-1의 수신여부를 확인해 주십시오.

วางรีโมทคอนโทรลไว้ในจุดที่กำหนดไว้ในข้อ 12 ชั่วคราว และตรวจสอบการรับสัญญาณของ A-1

Đặt tạm vào vị trí chỉ định 12, sau đó hãy tiến hành xác nhận việc nhận tín hiệu của A-1.

1

Hold down
계속 누름
กดค้างไว้
Ấn và giữ

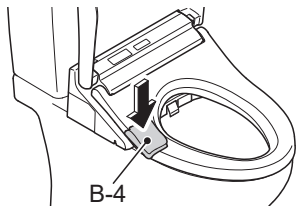

2

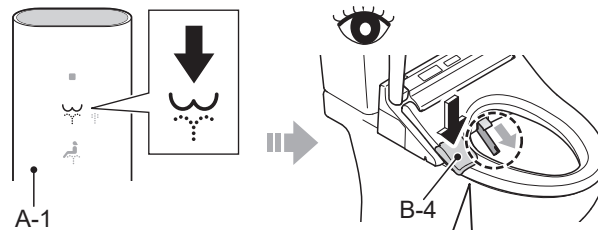

3

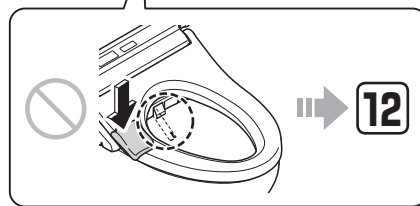
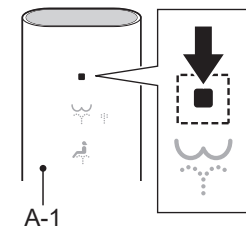

14

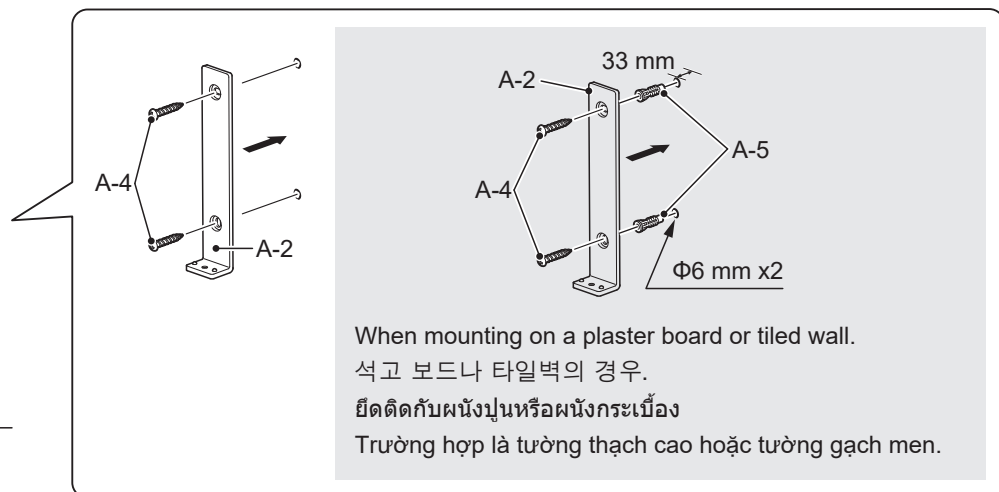
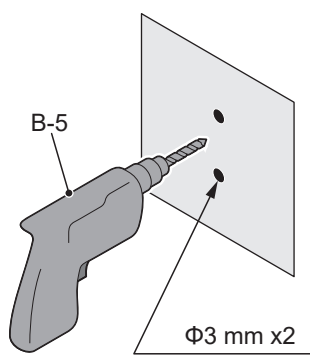

When mounting on a plaster board or tiled wall.

석고 보드나 타일벽의 경우.

ยึดติดกับผนังปูนหรือผนังกระเบื้อง

Trường hợp là tường thạch cao hoặc tường gạch men.

15

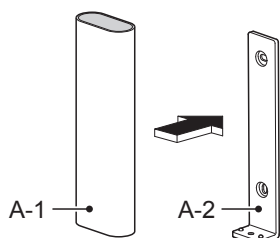

Anchored by magnet.

자석으로 고정됩니다.

ติดด้วยแม่เหล็ก

Cố định bằng nam châm.

Trial run / 시운전 / การทดสอบการทำงาน / Vận hành thử

- 16** Open the water shutoff valve (C-4).
 지수전 (C-4) 을 연다.
 เปิดวาล์วปิดน้ำ (C-4)
 Mở van khóa nước (C-4).

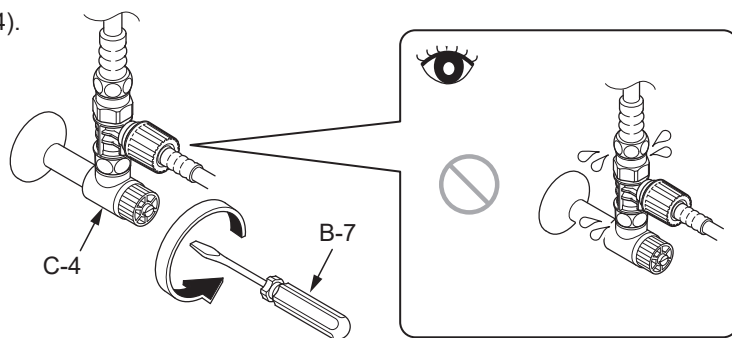

- 17** ① Hold down / 계속 누름
 กดค้างไว้ / Ấn và giữ

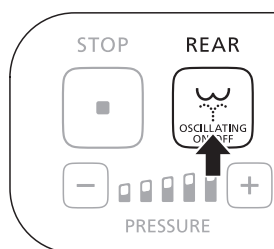
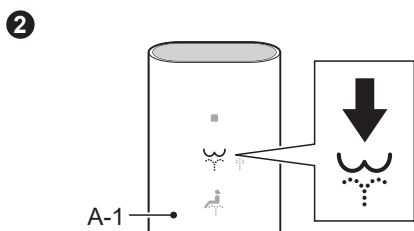
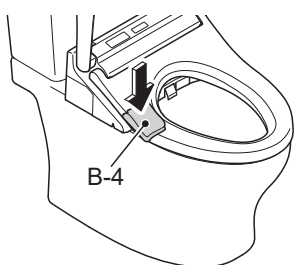

- 3** Hold down (about 1 minute) / 계속 누름 (약 1분)
 กดค้างไว้ (ประมาณ 1 นาที) / Ấn và giữ (khoảng 1 phút)

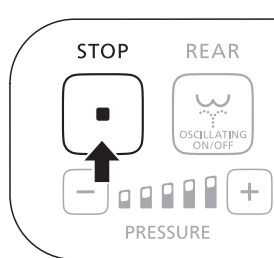
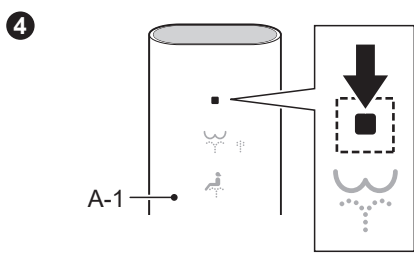
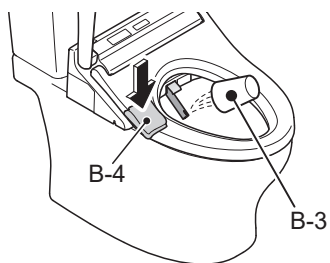

After trial run / 시운전 후 / หลังการทดสอบการทำงาน / Sau khi vận hành thử

18

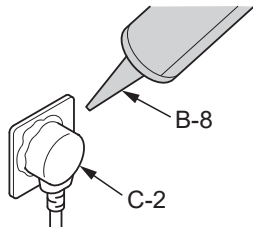

Installation complete
시공 완성
การติดตั้งเสร็จสมบูรณ์
Lắp đặt hoàn tất

Information for the installer / 시공업자님께 드리는 부탁 말씀
ข้อมูลสำหรับผู้ติดตั้ง / Thông tin dành cho cửa hàng lắp đặt

Fill in the necessary information on the warranty card and be sure to hand it to the customer.

취급설명서의 보증서에 필요사항을 기입한 후 반드시 고객에게 전해 주십시오.

ป้อนข้อมูลที่จำเป็นลงในบัตรรับประกันสินค้าและส่งให้แก่ลูกค้า

Điền các hạng mục cần thiết vào phiếu bảo hành sau đó đưa cho khách hàng.

Please explain the features and operation of the product to the customer.

제품의 기능, 사용방법에 대해서 사용자에게 설명해 주십시오.

อธิบายคุณสมบัติต่างๆ และการทำงานของผลิตภัณฑ์ให้ลูกค้าทราบ

Hãy giải thích cho khách hàng về cách sử dụng và tính năng của sản phẩm.

If the product will not be used for a long time (like when it is installed in an unoccupied, newly constructed building),

- Turn off power at the breaker on the distribution board or disconnect the power plug.
- To avoid leakage, remove the batteries from the remote control. (With remote control)

신축이나 공사 등으로 고객에게 제품이 전달되기까지 시간이 걸릴 경우;

- 분전반의 차단기를 OFF로 하거나 전원 플러그를 뽑아 주십시오.
- 건전지 누액의 누출을 방지하기 위해 리모컨에서 건전지를 분리하여 주십시오. (리모컨 포함 사양)

หากจะไม่ใช้งานผลิตภัณฑ์เป็นเวลานาน (เช่น เมื่อติดตั้งผลิตภัณฑ์ในตึกที่เพิ่งสร้างเสร็จ และยังไม่มีการใช้งาน)

- ให้สับเบรกเกอร์ไฟบนแผงไฟไปที่ตำแหน่งปิด (OFF)
- ถอดแบตเตอรี่ออกจากรีโมทคอนโทรลเพื่อป้องกันไม่ให้อายุการใช้งานสั้นลง (รุ่นที่ใช้รีโมท)

Nếu không sử dụng sản phẩm trong thời gian dài (chẳng hạn như lắp đặt tại nơi chưa có người ở, lắp đặt trong tòa nhà mới xây) thì phải:

- Ngắt cầu dao trên bảng điều khiển hoặc rút phích cắm nguồn điện.
- Để tránh rò rỉ, hãy tháo pin ra khỏi điều khiển. (Loại có điều khiển từ xa)

MEMO

